

# XM-222MK2

## SERVICE MANUAL

Ver 1.1 2002. 03

Canadian Model  
AEP Model  
UK Model  
E Model



### SPECIFICATIONS

Circuit system	OTL (output transformerless) circuit Pulse power supply
Inputs	RCA pin jacks High level input connector
Input level adjustment range	0.3 – 6 V (RCA pin jacks), 0.6 – 12 V (High level input)
Outputs	Speaker terminals
Speaker impedance	2 – 8 $\Omega$ (stereo) 4 – 8 $\Omega$ (when used as a bridging amplifier)
Maximum outputs	100 W $\times$ 2 (at 4 $\Omega$ ) 222 W (BTL, at 4 $\Omega$ )
Rated outputs (supply voltage at 14.4 V)	35 W $\times$ 2 (20 Hz – 20 kHz, 0.04% THD, at 4 $\Omega$ ) 40 W $\times$ 2 (20 Hz – 20 kHz, 0.1% THD, at 2 $\Omega$ ) 80 W (Monaural) (20 Hz – 20 kHz, 0.1% THD, at 4 $\Omega$ )
Frequency response	5 Hz – 80 kHz ( $\pm 3$ dB)
Harmonic distortion	0.005% or less (at 1 kHz, 4 $\Omega$ , 10 W)
Low-pass filter	80 Hz, –18 dB/oct
Power requirements	12 V DC car battery (negative ground)
Power supply voltage	10.5 – 16 V
Current drain	at rated output : 12 A (4 $\Omega$ , 35 W $\times$ 2) Remote input : 1.5 mA
Dimensions	Approx. 205 $\times$ 55 $\times$ 158 mm (w/h/d) not incl. projecting parts and controls
Mass	Approx. 1.6 kg not incl. accessories
Supplied accessories	Mounting screws (4) High level input cord (1) Protection cap (1)

*Design and specifications are subject to change without notice.*

## STEREO POWER AMPLIFIER

9-873-557-02  
2002C0400-1  
© 2002. 03

**Sony Corporation**  
e Vehicle Company  
Published by Sony Engineering Corporation

# SONY®

### SECTION 3 DIAGRAMS

#### 3-1. BLOCK DIAGRAM

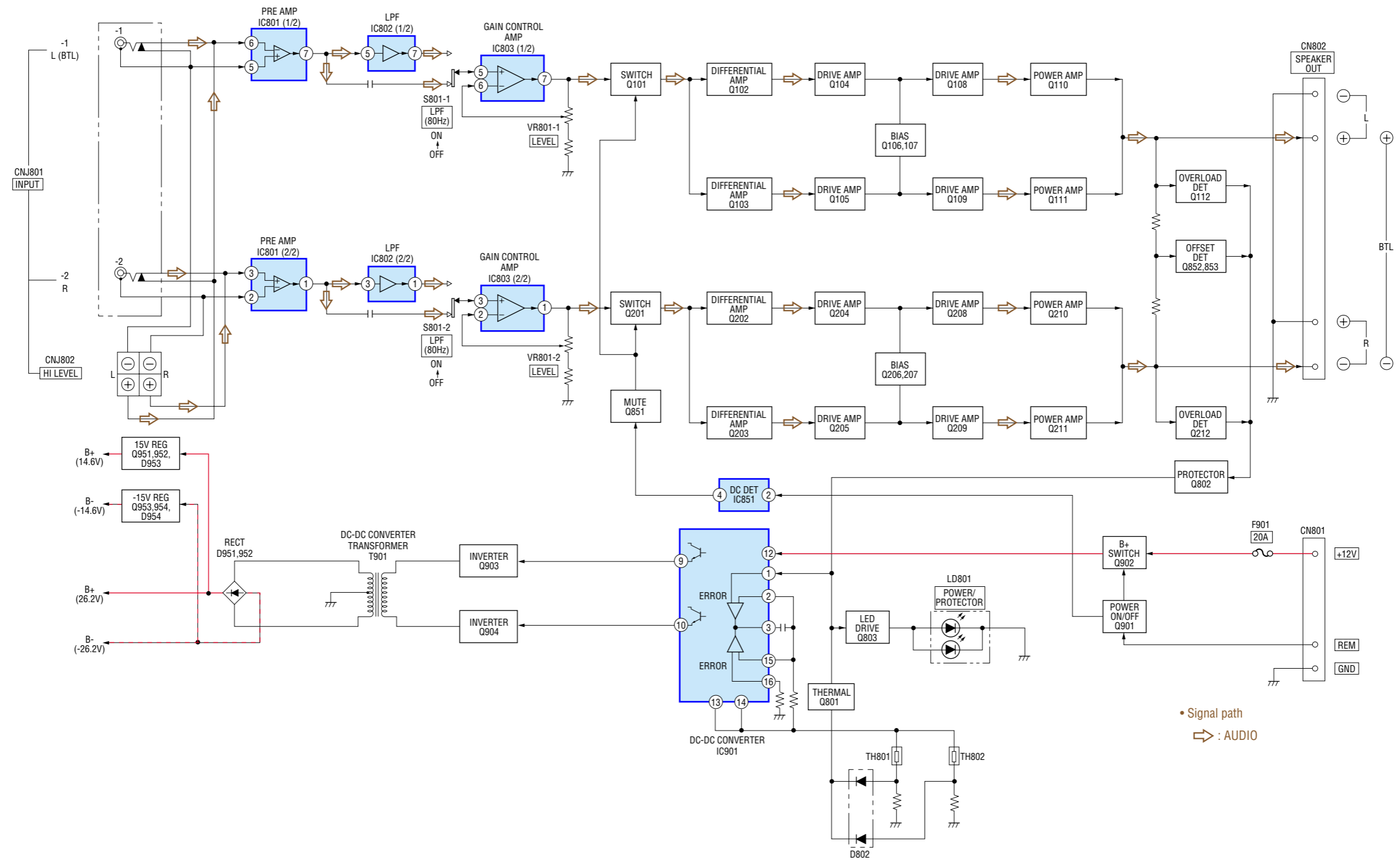

3-3. SCHEMATIC DIAGRAM • Refer to page 10 for IC Block Diagram and Common Note on Schematic Diagrams.

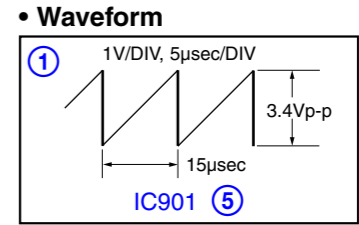
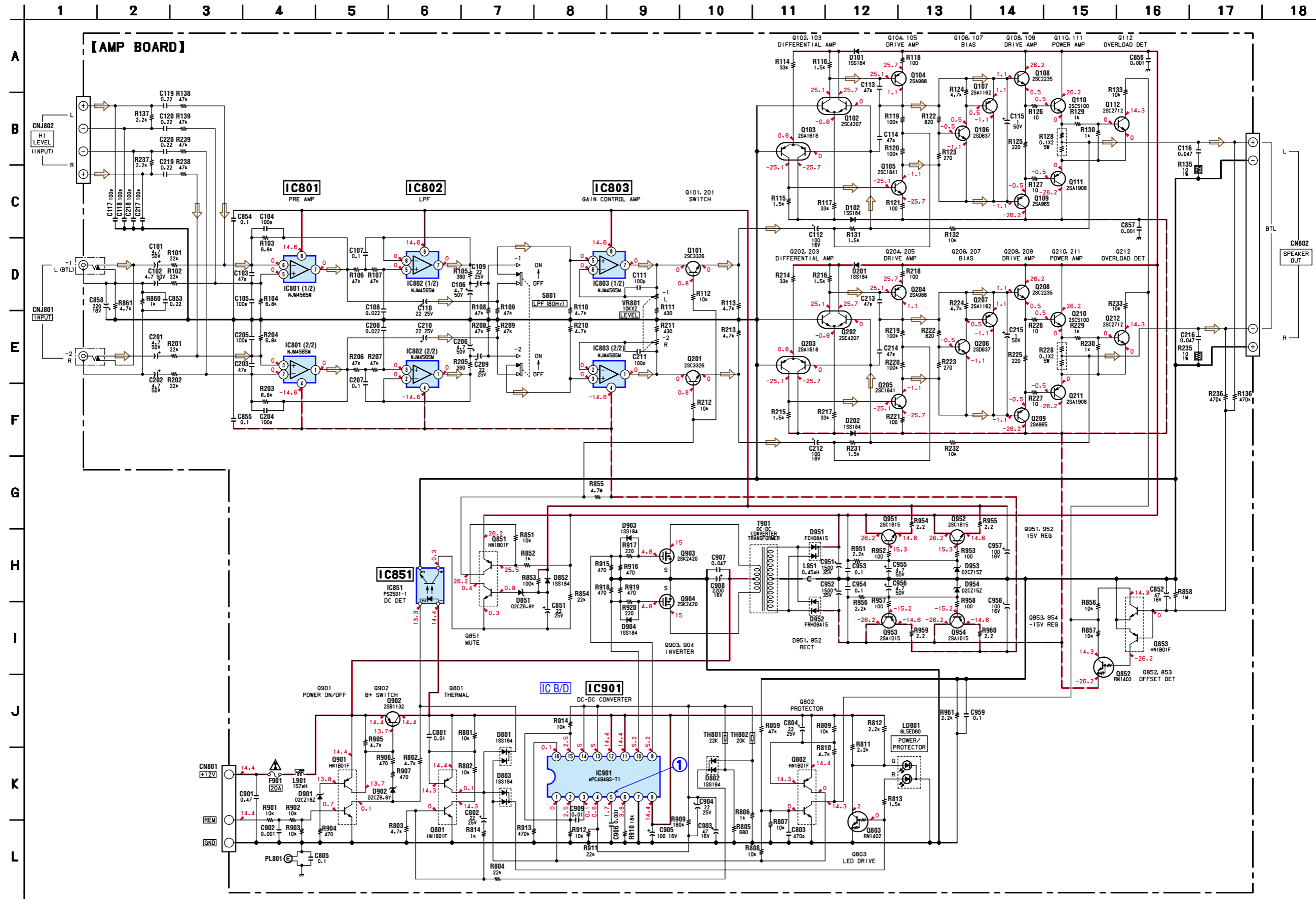

**Semiconductor Location**

Ref. No.	Location
D101	G-10
D102	G-9
D201	G-7
D202	G-6
D801	F-11
D802	E-11
D803	F-11
D851	E-10
D852	F-5
D901	D-10
D902	D-11
D903	D-9
D904	D-8
D951	B-7
D952	B-6
D953	D-4
D954	D-3
IC801	E-3
IC802	F-3
IC803	H-3
IC851	E-10
IC901	D-8
LD801	F-14
Q101	F-6
Q102	G-10
Q103	G-9
Q104	G-10
Q105	G-9
Q106	I-10
Q107	H-9
Q108	H-10
Q109	H-9
Q110	J-10
Q111	J-9
Q112	G-9
Q201	G-5
Q202	G-6
Q203	G-6
Q204	G-7
Q205	G-6
Q206	I-6
Q207	H-6
Q208	H-7
Q209	H-6
Q210	J-7
Q211	J-6
Q212	G-5
Q801	E-11
Q802	E-12
Q803	F-13
Q851	E-10
Q852	E-12
Q853	E-12
Q901	D-10
Q902	D-10
Q903	B-9
Q904	B-10
Q951	C-4
Q952	C-4
Q953	C-4
Q954	C-4

**THIS NOTE IS COMMON FOR PRINTED WIRING BOARDS AND SCHEMATIC DIAGRAMS.**  
(In addition to this, the necessary note is printed in each block.)

**for schematic diagram:**

- All capacitors are in  $\mu\text{F}$  unless otherwise noted.  $\text{pF}$ :  $\mu\text{F}$  50 WV or less are not indicated except for electrolytics and tantalums.
- All resistors are in  $\Omega$  and  $1/4\text{W}$  or less unless otherwise specified.
- : nonflammable resistor.

**Note:**

The components identified by mark  $\Delta$  or dotted line with mark  $\Delta$  are critical for safety. Replace only with part number specified.

**Note:**

Les composants identifiés par une marque  $\Delta$  sont critiques pour la sécurité. Ne les remplacer que par une pièce portant le numéro spécifié.

- : B+ Line.
- : B- Line.
- Power voltage is dc 14.4V and fed with regulated dc power supply from +12V and REM terminals.
- Voltage is dc with respect to ground under no-signal condition.
- Voltages are taken with a VOM (Input impedance 10 M $\Omega$ ). Voltage variations may be noted due to normal production tolerances.
- Waveforms are taken with an oscilloscope. Voltage variations may be noted due to normal production tolerances.
- Circled numbers refer to waveforms.
- Signal path.
- : AUDIO

**for printed wiring boards:**

- : parts extracted from the component side.
- : Pattern from the side which enables seeing.

**IC Block Diagram**

**IC901  $\mu\text{PC494GS-T1}$**

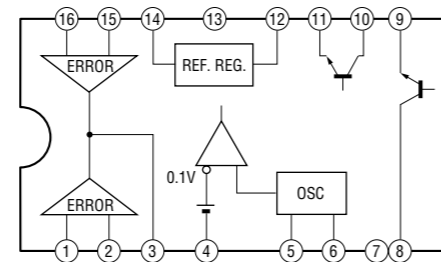

**SECTION 4  
EXPLODED VIEW**

**NOTE:**

- The mechanical parts with no reference number in the exploded views are not supplied.
- Items marked "\*" are not stocked since they are seldom required for routine service. Some delay should be anticipated when ordering these items.

**Color Indication of Appearance Parts**

Example :  
KNOB, BALANCE (WHITE) ... (RED)

↑  
Parts Color Cabinet's Color

- Accessories are given in the last of this parts list.

The components identified by mark  $\Delta$  or dotted line with mark  $\Delta$  are critical for safety. Replace only with part number specified.

Les composants identifiés par une marque  $\Delta$  sont critiques pour la sécurité. Ne les remplacer que par une pièce portant le numéro spécifié.

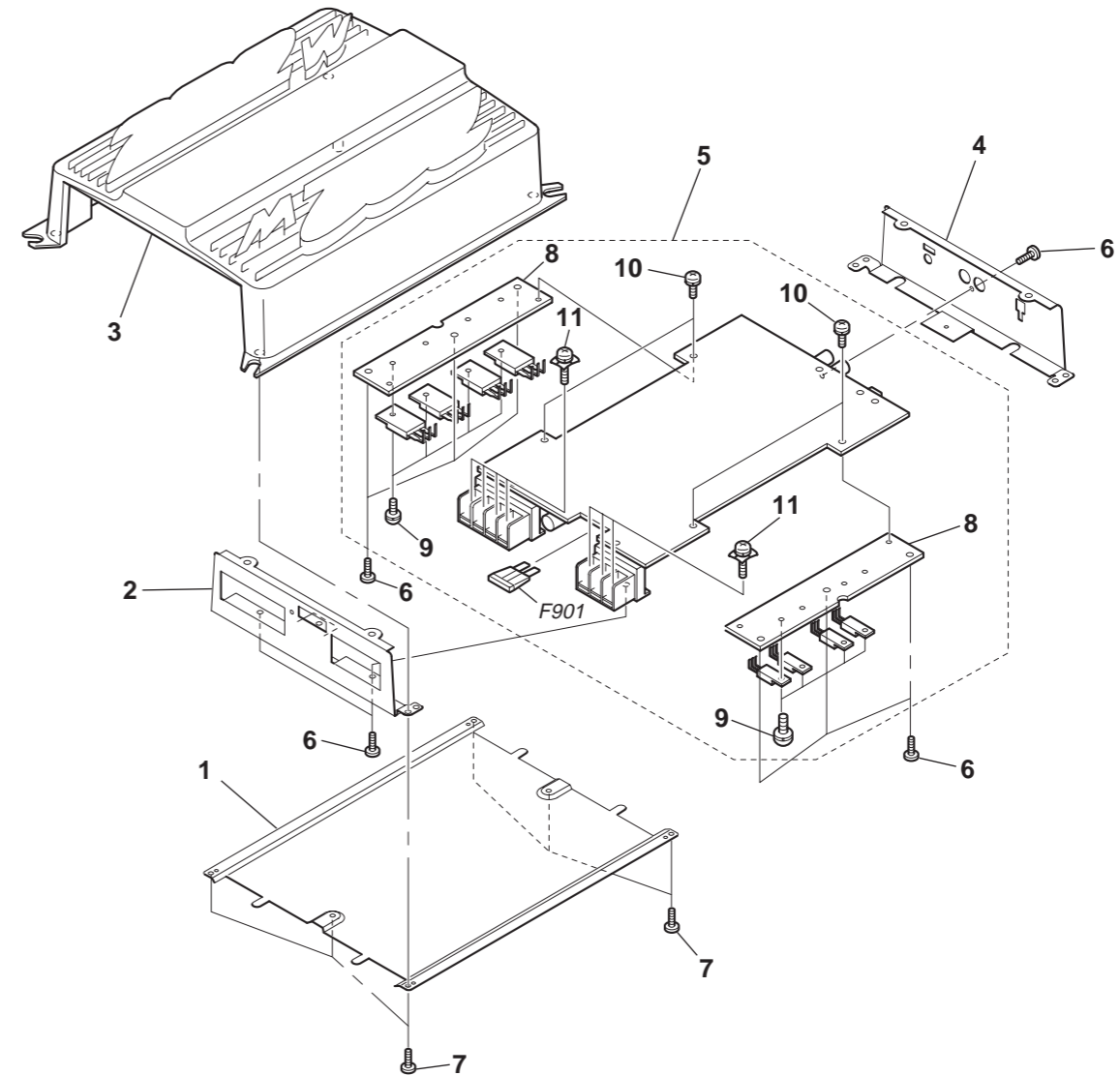

Ref. No.	Part No.	Description	Remark	Ref. No.	Part No.	Description	Remark
1	3-240-641-01	PLATE, BOTTOM		7	7-685-545-14	SCREW +BTP 3X6 TYPE2 N-S	
2	3-238-672-01	PANEL, FRONT		8	3-240-642-01	HEAT SINK (SUB 2CH)	
3	3-238-671-01	HEAT SINK (CHINESE MADE)		9	3-225-183-01	SCREW (+PSW.TT.3XL)	
3	3-238-671-11	HEAT SINK (JAPAN MADE)		10	3-225-184-01	SCREW (+PS.TT.3X6)	
4	3-238-673-01	PANEL, REAR		11	3-912-432-01	SCREW (+-B)	
5	A-3274-223-A	AMP BOARD, COMPLETE		$\Delta$ F901	1-532-732-11	FUSE (BLADE TYPE) (AUTO FUSE) 20A	
6	7-685-646-79	SCREW +BVTP 3X8 TYPE2 IT-3					