

MEX-5DI

SERVICE MANUAL

Ver 1.0 2002. 04

US Model
Canadian Model
AEP Model
UK Model
E Model



• The tuner and CD sections have no adjustments.

Model Name Using Similar Mechanism	CDX-MP70
CD Drive Mechanism Type	MG-550T-156
Optical Pick-up Name	DAX-23E

SPECIFICATIONS

CD player section

Signal-to-noise ratio 95 dB
Frequency response 10 – 20,000 Hz
Wow and flutter Below measurable limit

MS section

Signal-to-noise ratio 90 dB
Frequency response 10 – 20,000 Hz

Tuner section

FM

Tuning range 87.5 – 107.9 MHz (US, Canadian Model)
87.5 – 108.0 MHz (AEP, UK, E Model)
Antenna terminal External antenna connector
Intermediate frequency 10.7 MHz/450 kHz
Usable sensitivity 8 dBf
Selectivity 75 dB at 400 kHz
Signal-to-noise ratio 66 dB (stereo),
72 dB (mono)
Harmonic distortion at 1 kHz
0.6% (stereo),
0.3% (mono)
Separation 35 dB at 1 kHz
Frequency response 30 – 15,000 Hz

AM (US, Canadian Model)

Tuning range 530 – 1,710 kHz
Antenna terminal External antenna connector
Intermediate frequency 10.7 MHz/450 kHz
Sensitivity 30 μ V

MW/LW (AEP, UK, E Model)

Tuning range MW : 531 – 1,602 kHz
LW : 153 – 279 kHz
Aerial terminal External aerial connector
Intermediate frequency 10.7 MHz/450 kHz
Sensitivity MW : 30 μ V
LW : 40 μ V

General

Outputs Audio outputs (front/rear)
Subwoofer output (mono)
Power antenna relay control terminal
Power amplifier control terminal
Inputs Telephone ATT control terminal
Illumination control terminal
BUS control input terminal
BUS audio input/AUX IN terminal
Antenna input terminal
Tone controls Bass \pm 8 dB at 100 Hz
Treble \pm 8 dB at 10 kHz
Loudness +8 dB at 100 Hz
+2 dB at 10 kHz
Power requirements 12 V DC car battery
(negative ground)
Dimensions Approx. 178 \times 50 \times 178 mm
(7 1/8 \times 2 \times 7 1/8 in.) (w/h/d)
Mounting dimensions Approx. 182 \times 53 \times 157 mm
(7 1/4 \times 2 1/8 \times 6 1/4 in.) (w/h/d)

– Continued on next page –

MG-MS/FM/AM COMPACT DISC PLAYER

US, Canadian Model

MG-MS/FM/MW/LW COMPACT DISC PLAYER

AEP, UK, E Model

9-874-009-01
2002D0400-1
© 2002. 04

Sony Corporation
e Vehicle Company
Published by Sony Engineering Corporation

SONY®

4-3. BLOCK DIAGRAM — CD SECTION —

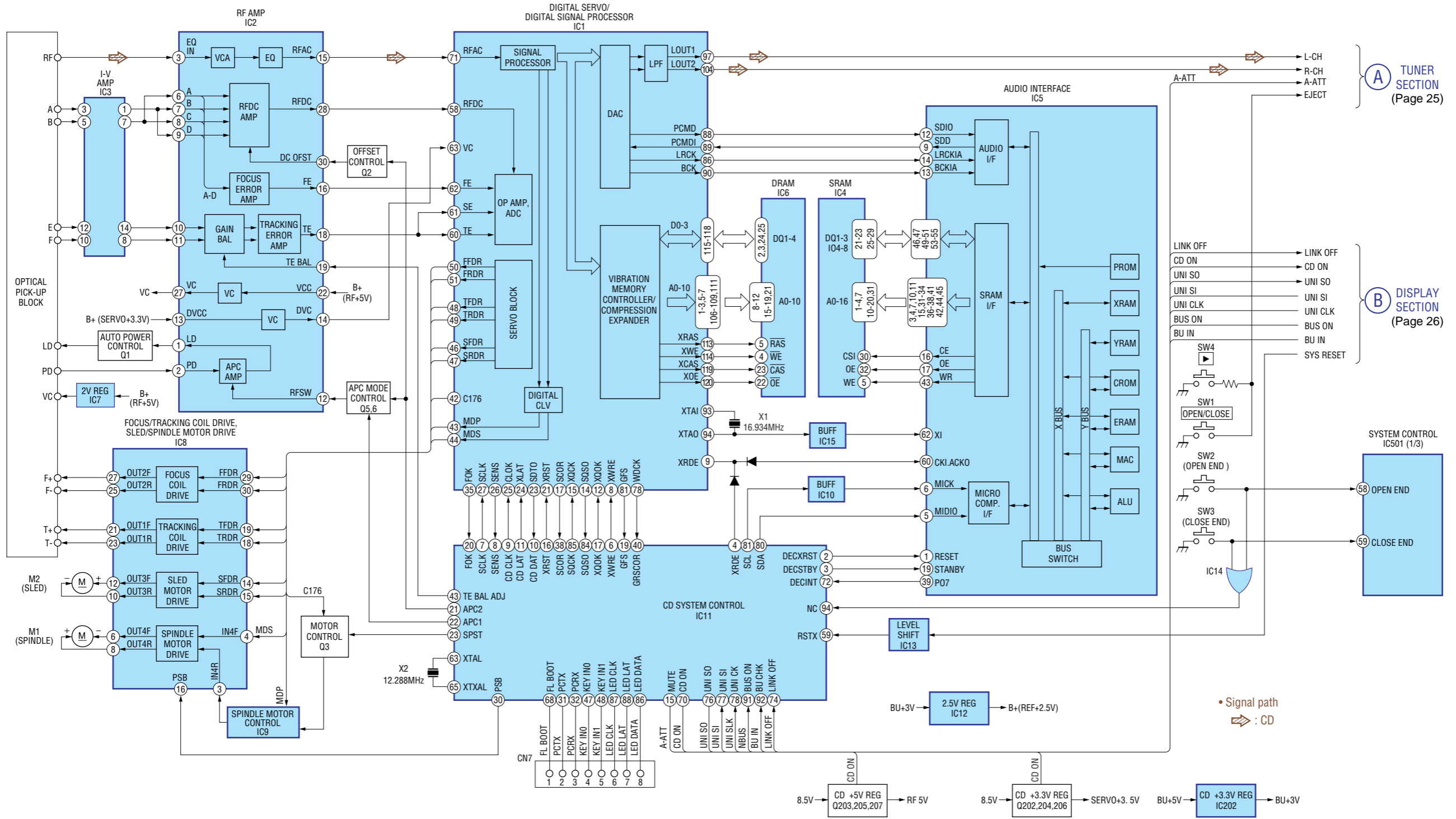

4-4. BLOCK DIAGRAM — TUNER SECTION —

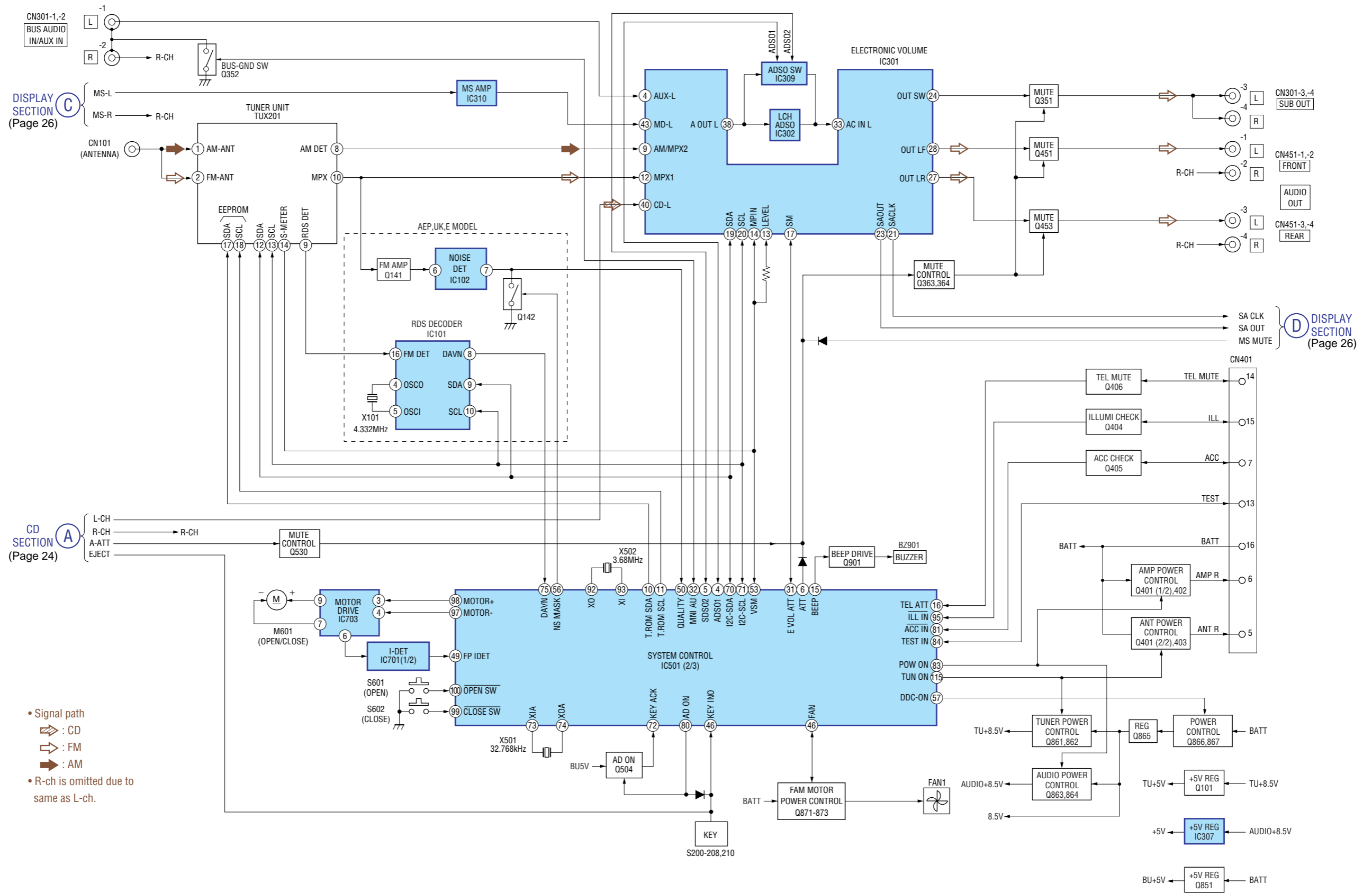

4-5. BLOCK DIAGRAM — DISPLAY SECTION —

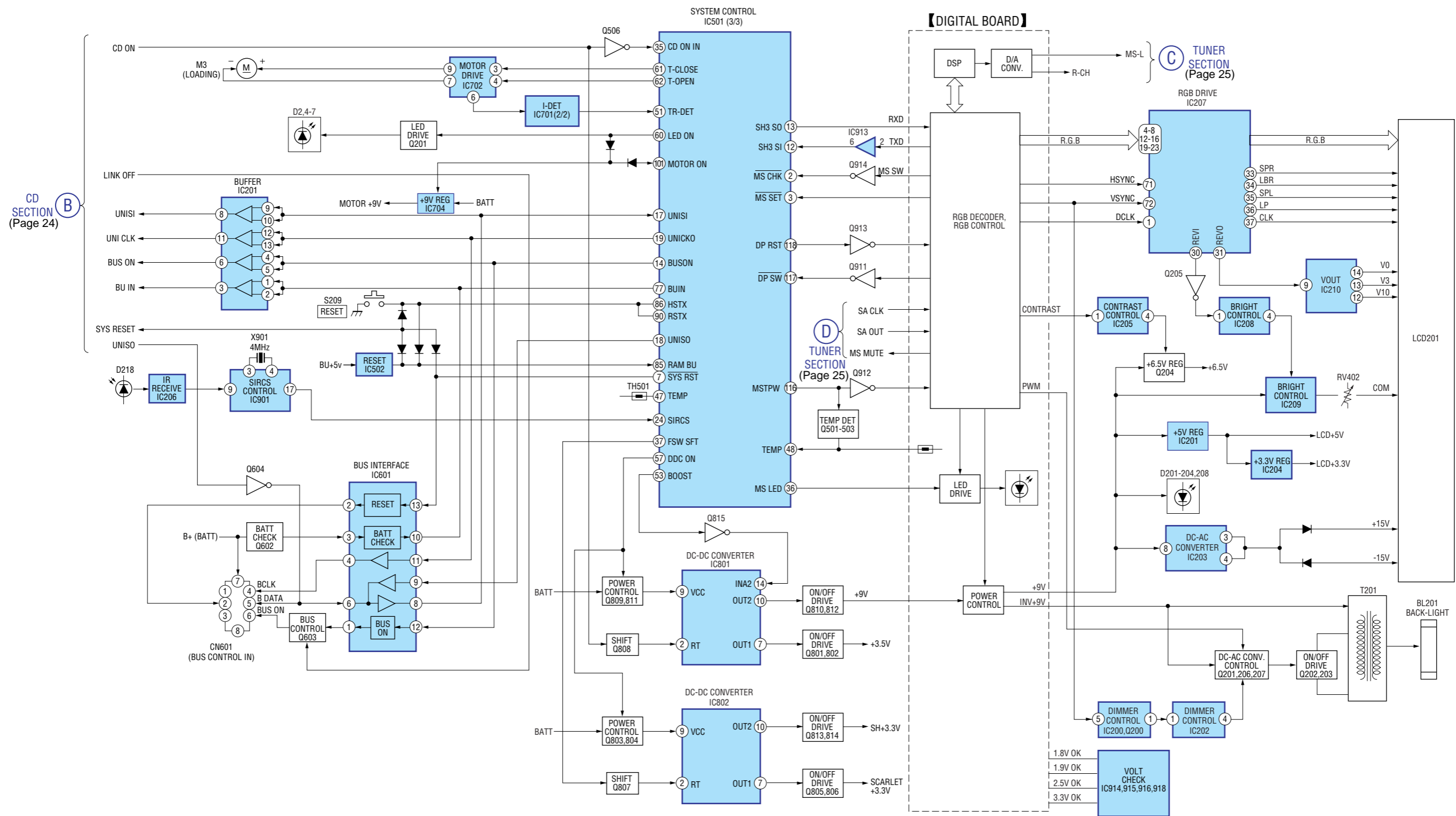

4-6. CIRCUIT BOARDS LOCATION

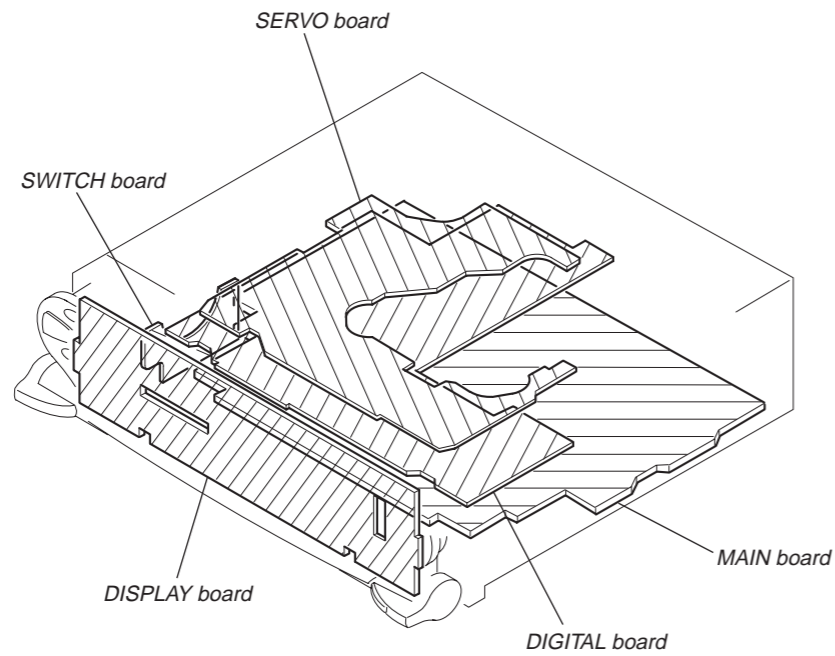

• Waveforms

— Servo Board —

(MODE: CD PLAY)

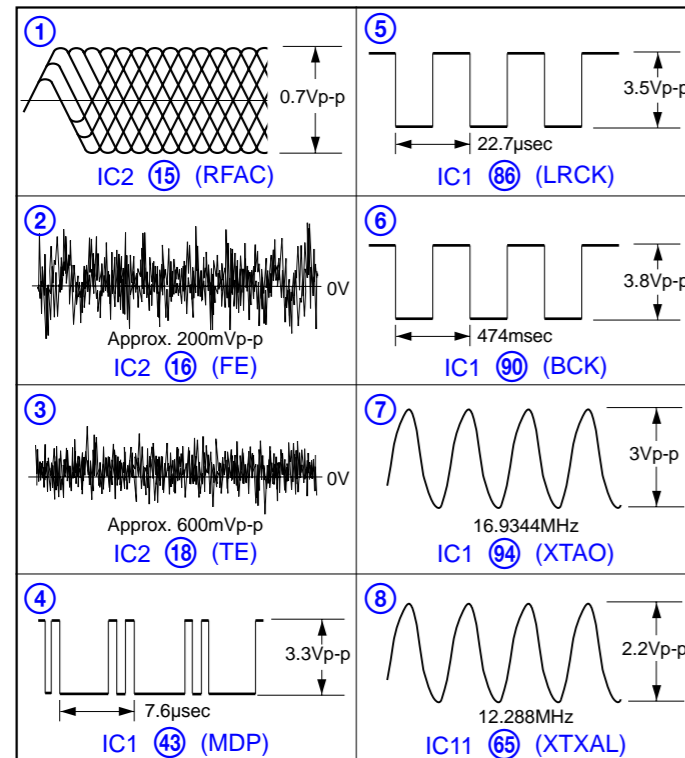

— Main Board —

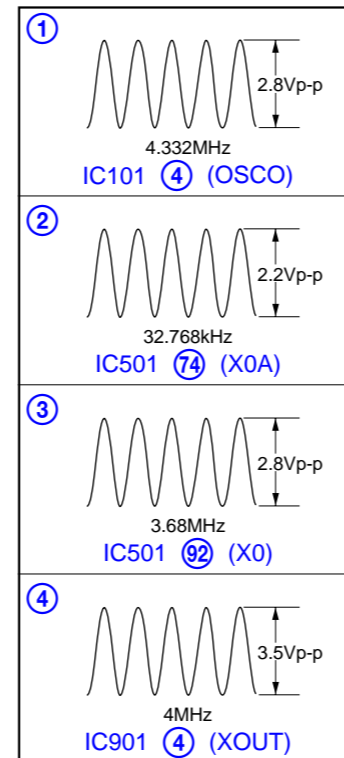

THIS NOTE IS COMMON FOR PRINTED WIRING BOARDS AND SCHEMATIC DIAGRAMS.
(In addition to this, the necessary note is printed in each block.)

for schematic diagram:

- All capacitors are in μF unless otherwise noted. pF: $\mu\mu\text{F}$
- 50 WV or less are not indicated except for electrolytics and tantalums.
- All resistors are in Ω and $1/4\text{ W}$ or less unless otherwise specified.
- % : indicates tolerance.
- Δ : internal component.
- \square : panel designation.

Note:

The components identified by mark Δ or dotted line with mark Δ are critical for safety. Replace only with part number specified.

Note:

Les composants identifiés par une marque Δ sont critiques pour la sécurité. Ne les remplacer que par une pièce portant le numéro spécifié.

- — : B+ Line.
- Power voltage is dc 14.4V and fed with regulated dc power supply from ACC and BATT cords.
- Voltages are taken with a VOM (Input impedance 10 M Ω). Voltage variations may be noted due to normal production tolerances.
- Waveforms are taken with a oscilloscope. Voltage variations may be noted due to normal production tolerances.
- Circled numbers refer to waveforms.
- Signal path.
 - \Rightarrow : FM
 - \Rightarrow : AM/MW/LW
 - \Rightarrow : CD

for printed wiring boards:

- \circ : parts extracted from the component side.
- \square : parts extracted from the conductor side.
- \blacksquare : parts mounted on the conductor side.
- \circ : Through hole.
- ■ : Pattern from the side which enables seeing. (The other layer's patterns are not indicated.)

Caution:

Pattern face side: Parts on the pattern face side seen from the (Side B) pattern face are indicated.
Parts face side: Parts on the parts face side seen from the (Side A) parts face are indicated.

• Refer to page 27 for Waveforms.

4-8. SCHEMATIC DIAGRAM — CD MECHANISM SECTION (1/2) — • Refer to page 40 for IC Block Diagrams.

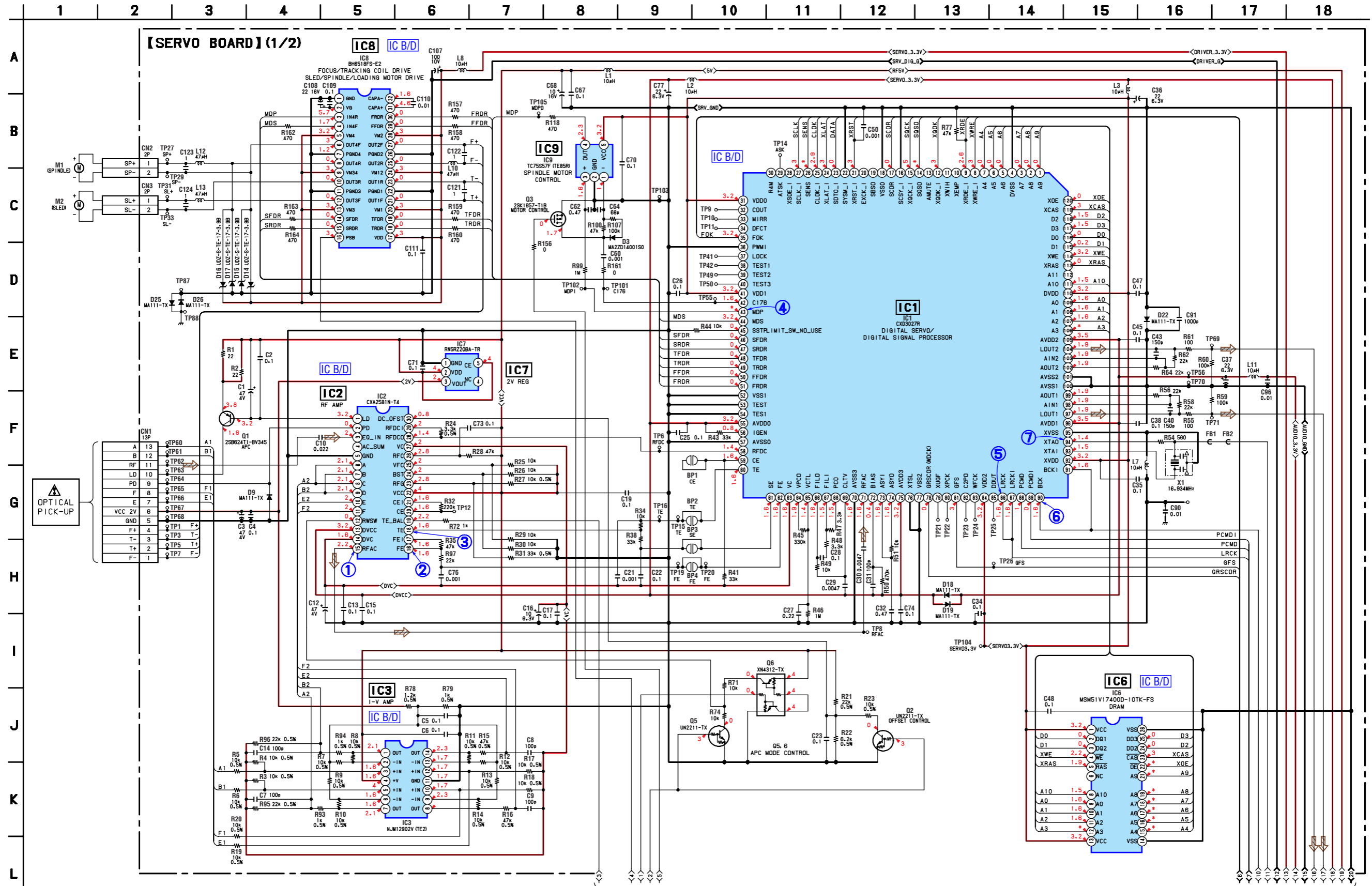

A	13	TP60	
B	12	TP61	
RF	11	TP62	
LD	10	TP63	
F	9	TP64	
F	8	TP65	F1
E	7	TP66	E1
VCC	2V	TP67	
GND	5	TP68	
F+	4	TP1	F+
T-	3	TP3	T-
T+	2	TP5	T+
F-	1	TP7	F-

Note:
 • Voltage is dc with respect to ground under no-signal conditions.
 no mark : CD PLAY
 * : Impossible to measure

1
 SERVO BOARD (2/2)
 (Page 31)

• Refer to page 27 for Waveform.

4-11. SCHEMATIC DIAGRAM — MAIN SECTION (1/4) — • Refer to page 43 for IC Block Diagrams.

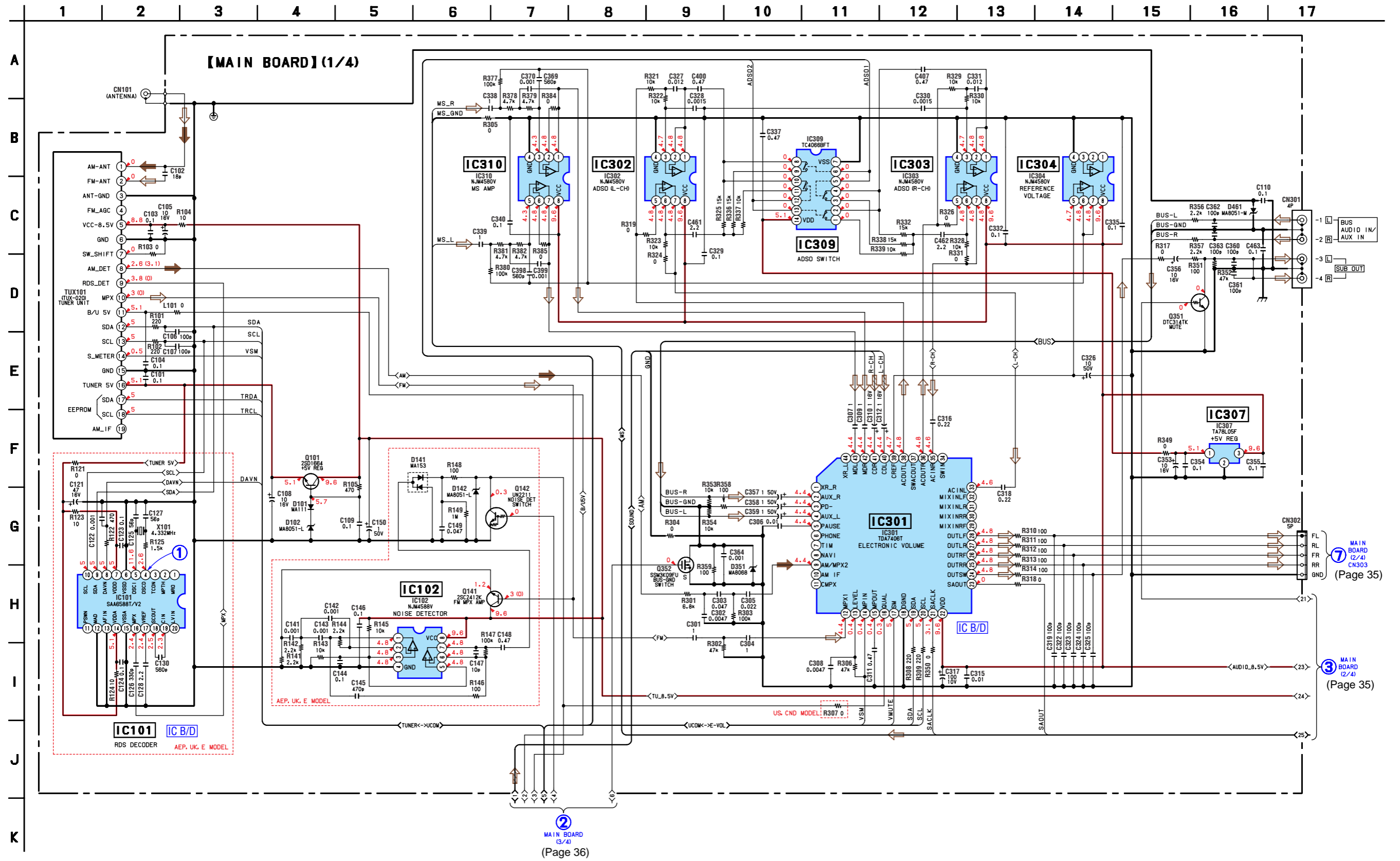

Note:
 • Voltage is dc with respect to ground under no-signal (detuned) condition.
 no mark : FM
 () : AM/MW/LW

4-12. SCHEMATIC DIAGRAM — MAIN SECTION (2/4) —

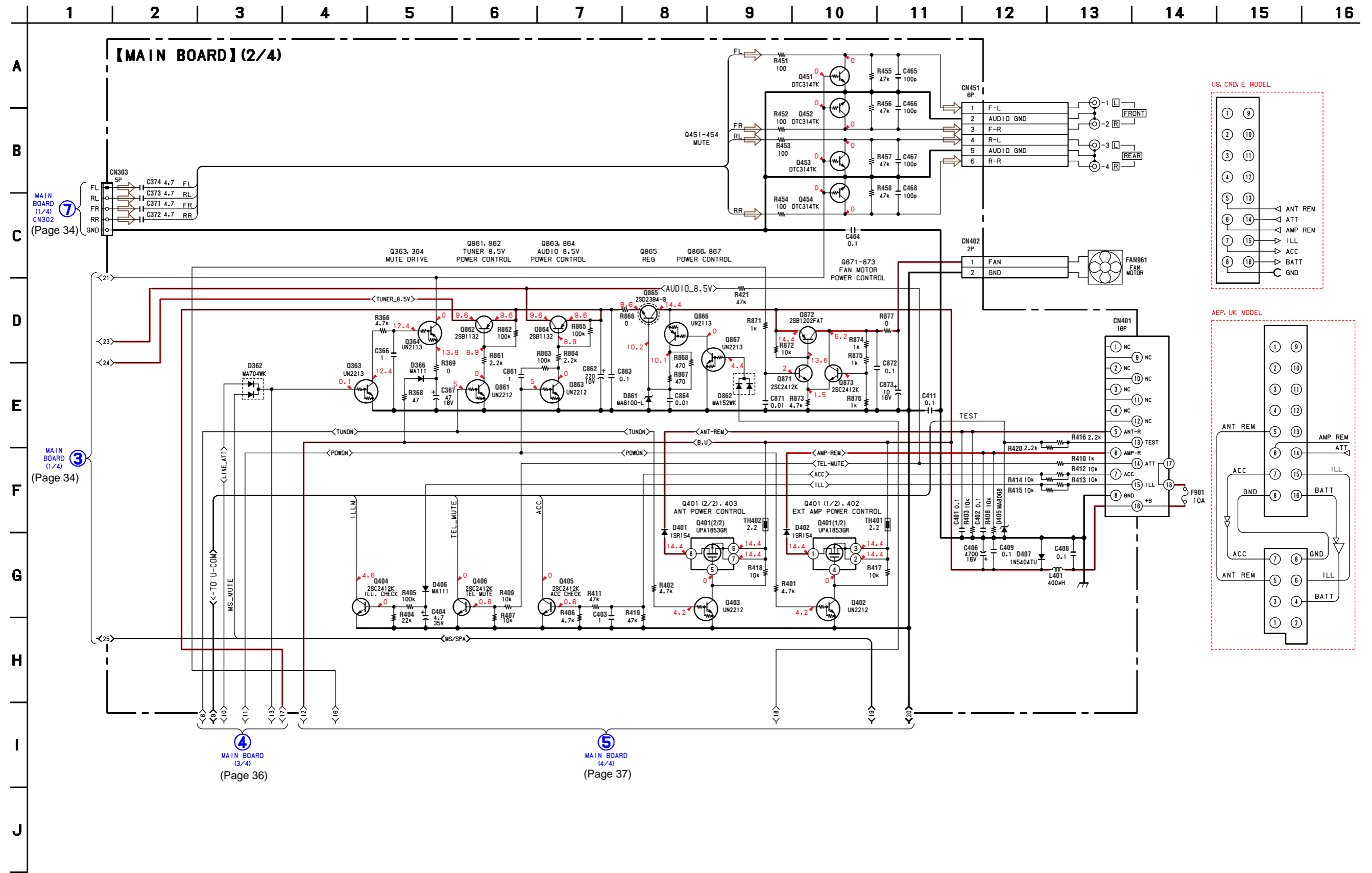

Note:
 • Voltage is dc with respect to ground under no-signal (detuned) condition.
 no mark : FM

• Refer to page 27 for Waveforms.

4-13. SCHEMATIC DIAGRAM — MAIN SECTION (3/4) — • Refer to page 45 for IC Block Diagrams.

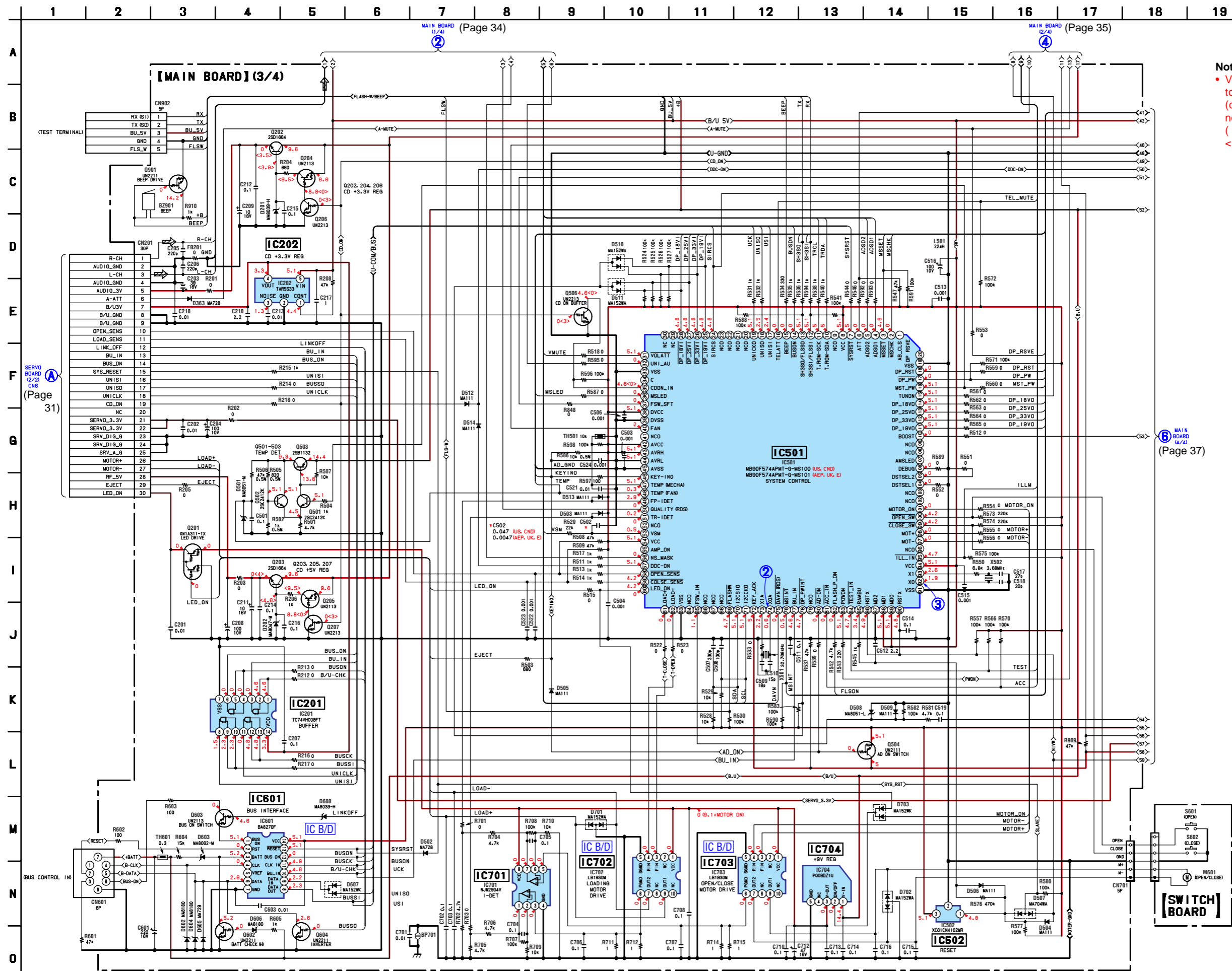

Note:

- Voltage is dc with respect to ground under no-signal (detuned) condition.
- no mark : FM
- () : AM/MW/LW
- < > : CD PLAY

4-16. SCHEMATIC DIAGRAM — DISPLAY SECTION — • Refer to page 45 for IC Block Diagram.

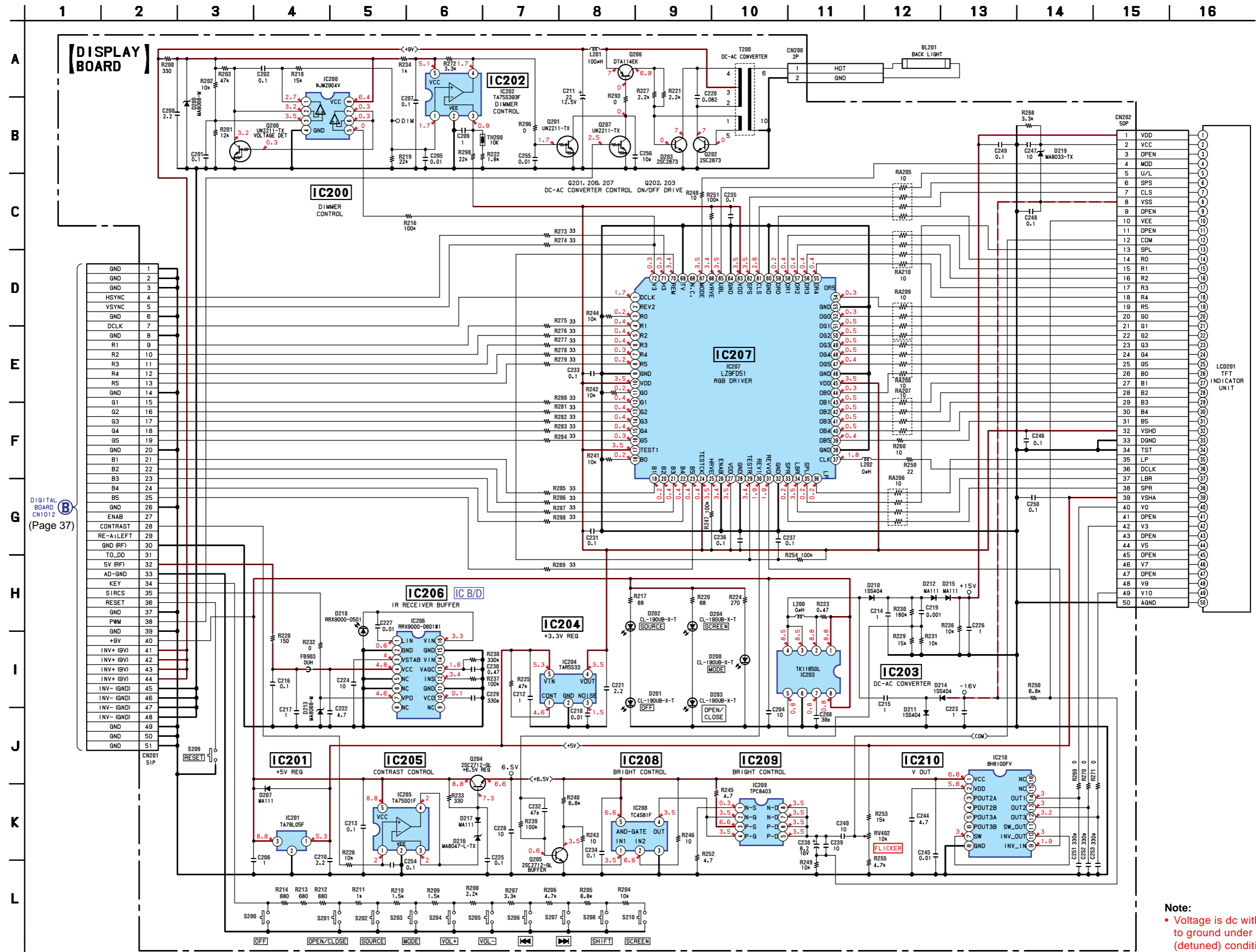

• IC BLOCK DIAGRAMS

IC1 CXD3027R

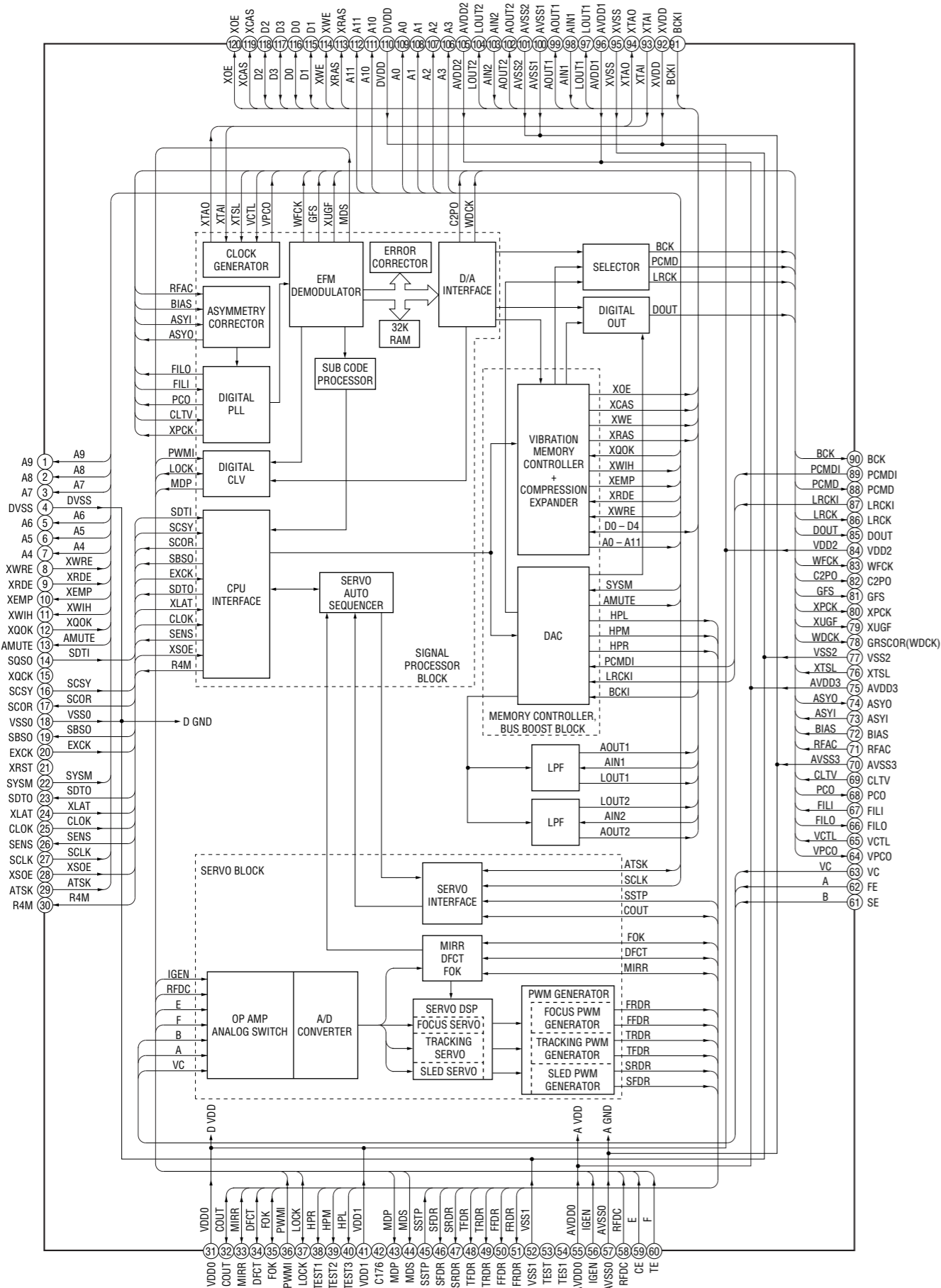

IC2 CXA2581N-T4

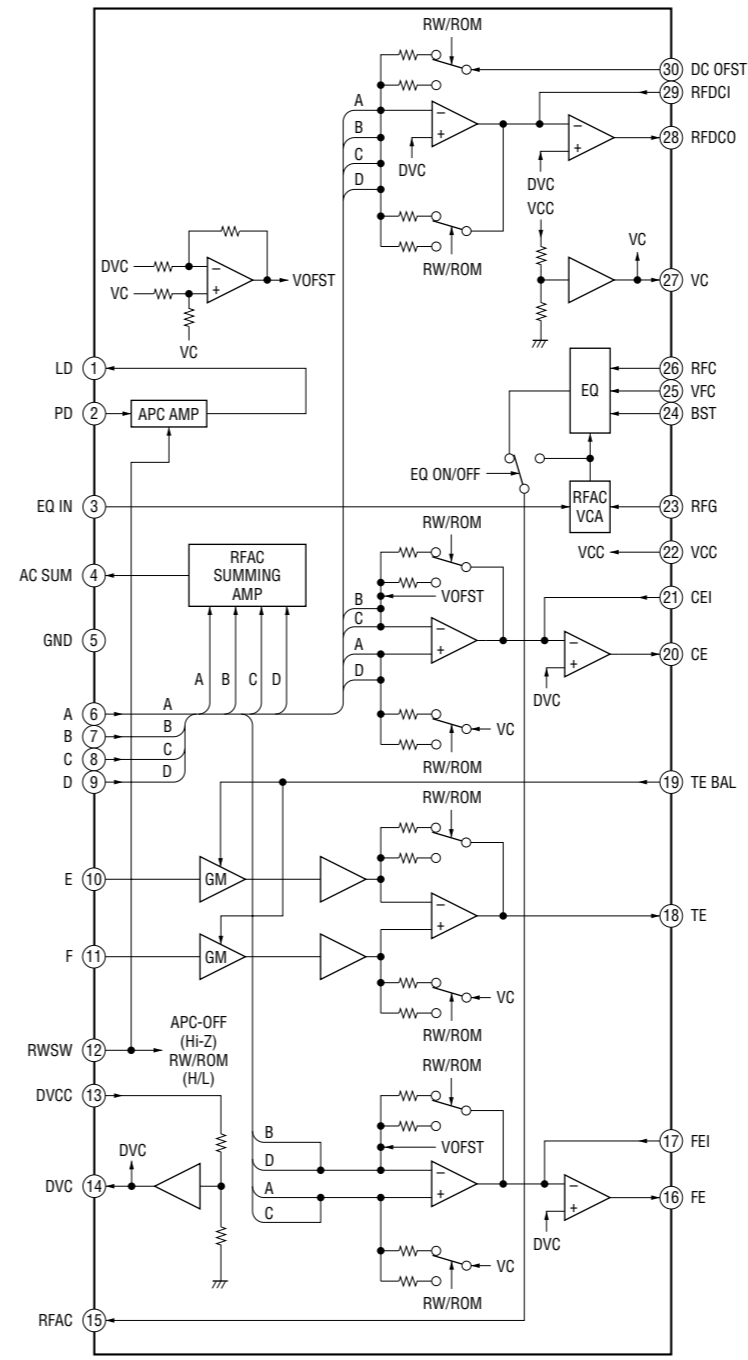

IC3 NJM12902V (TE2)

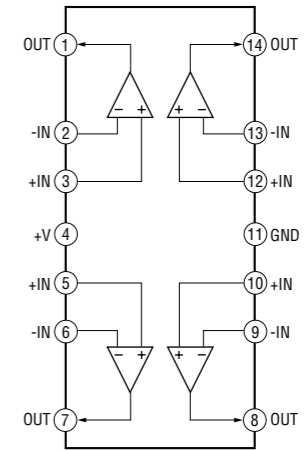

IC8 BH6518FS-E2

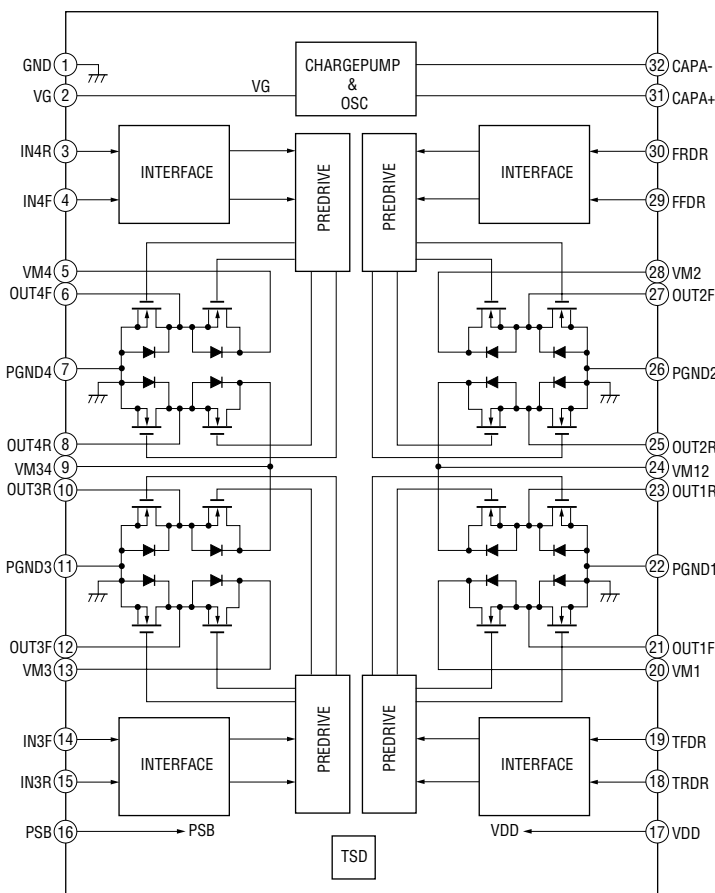

IC6 MSM51V1740D-10TK-FS

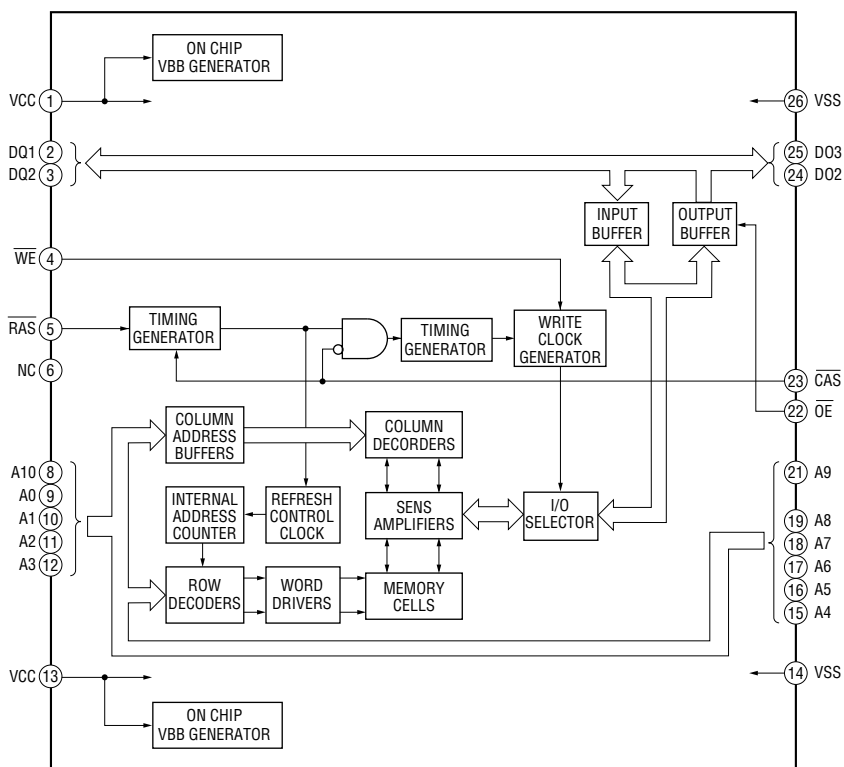

IC5 CXD9684R-004

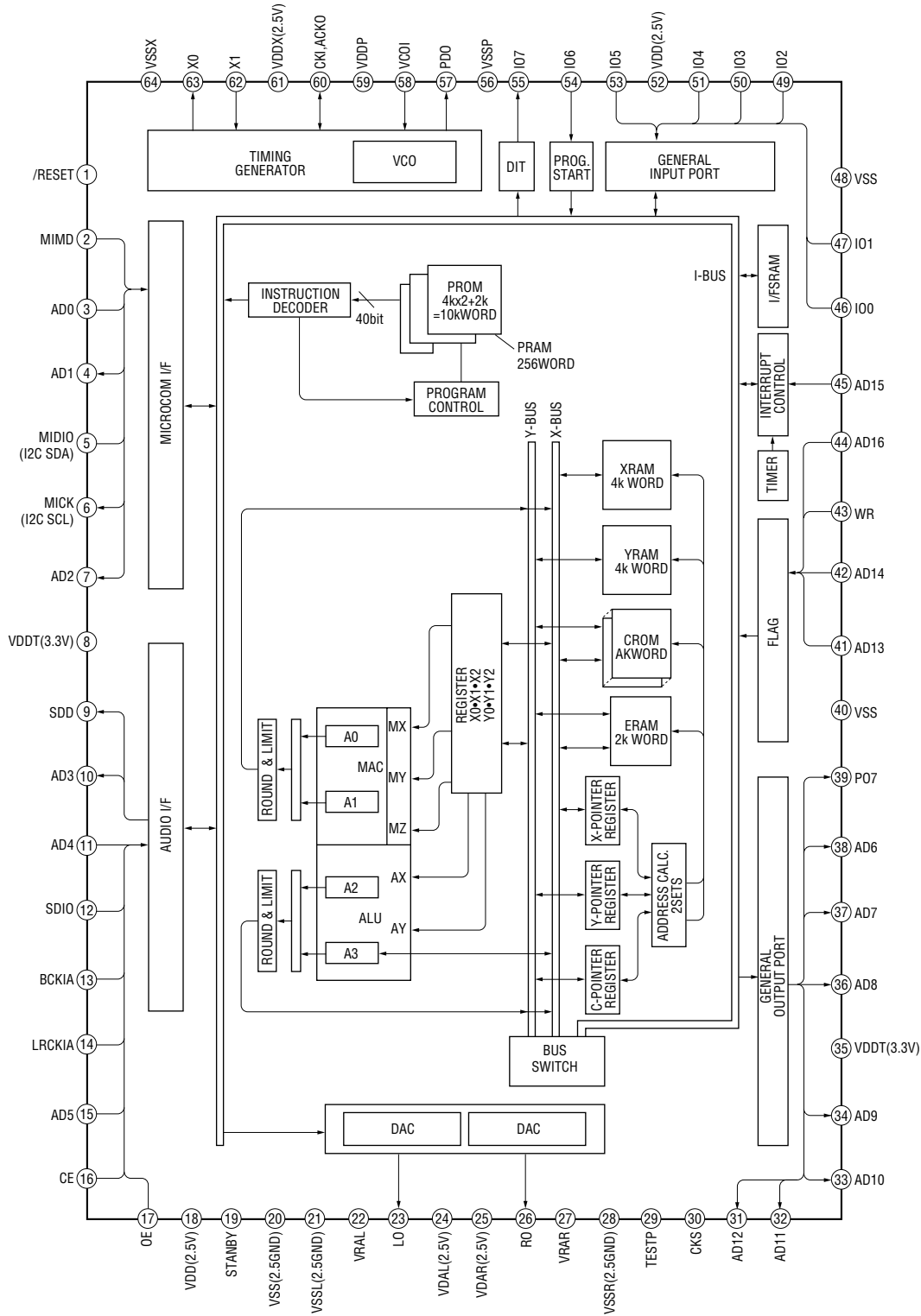

IC4 W24L010AT-12-EL15

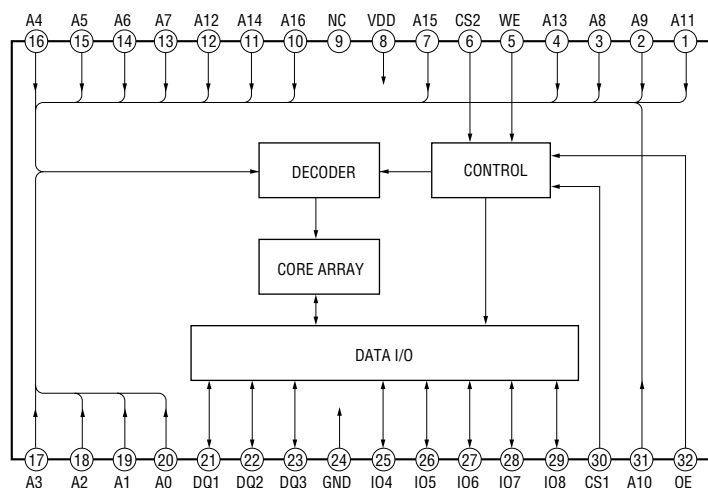

IC101 SAA6588T/V2

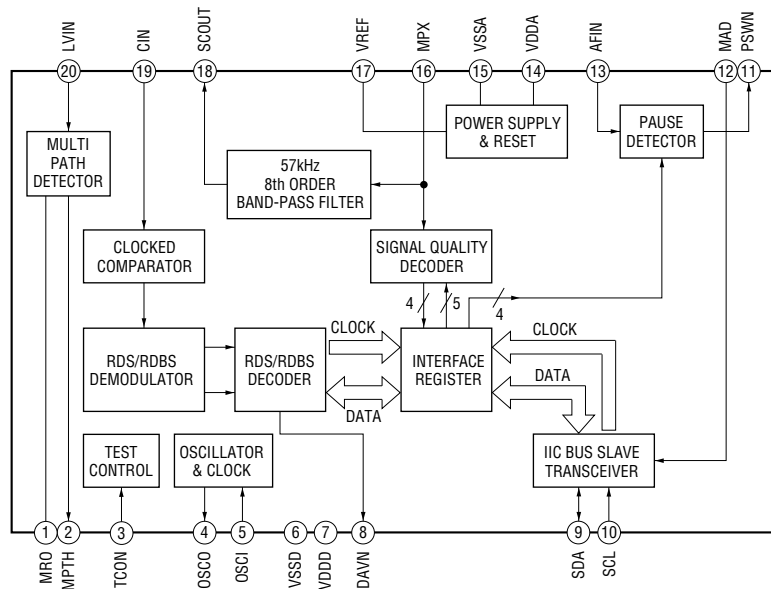

IC301 TDA7406T

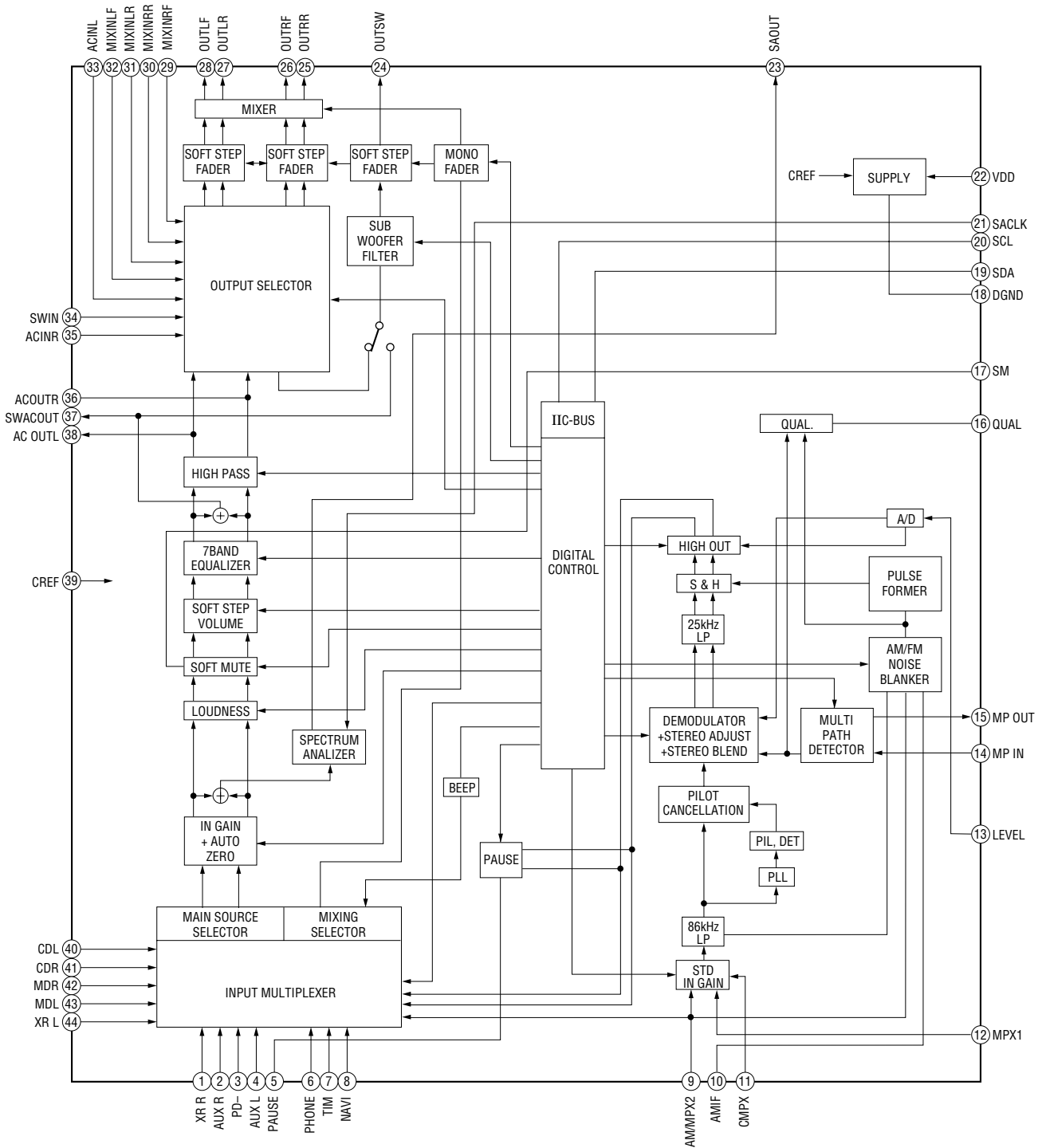

IC601 BA8270F

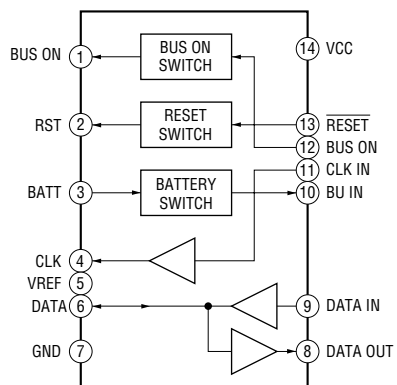

**IC702 LB1930M
IC703 LB1930M**

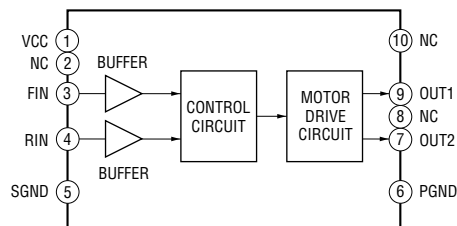

**IC801 TL1451ACDB
IC802 TL1451ACDB**

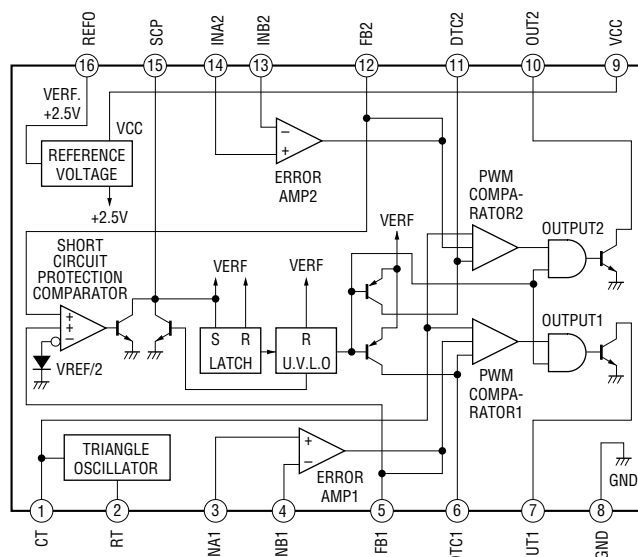

IC206 RRX9000-0601#1

